



# HM 130 00

## EXTERNAL MOTORISED ROLLER BLIND SYSTEMS

Designed to control the entry of natural light, heat and solar energy from the outside, external screens allow you to extend outdoor living areas while maximising the advantages of glass.

This stylish heavy duty motorised external roller system is ideal for extra large sized blinds in a commercial or domestic application. The HM 130 00 is motorised for maximum ease of use and offers a choice of powder coated side channels or stainless steel guide cables. A weighted base bar ensures ideal presentation of the fabric at all times. Helioscreen external systems will reduce the sun's heat by up to 90% and come with a 5 year warranty.

**MINIMUM WIDTH:** 800mm  
**MAXIMUM WIDTH:** 5400mm  
**MAXIMUM DROP:** 3800mm  
**LINKABLE:** NO

### BRACKETS

- 140 x 75mm fixing plate, 150mm Projection. 6mm thick powder coated aluminium

### TUBE

- 130mm extruded aluminium
- 3mm wall thickness

### GUIDING SYSTEM OPTIONS

- 316 Marine Grade Stainless steel cables and cable fixings
- Cable fixings: choice of wall fix, timber deck fix, or masonry bottom fix
- Rectangular channels 20 x 26mm

### BASE BAR

- Lead weighted 18mm x 35mm extruded aluminium base bar Helio style
- Lead weighted Teardrop base bar 22 x 37 mm
- Clear anodised or custom powder-coated finish

### CONTROL

- Motorised with remote control from Somfy
- Operate up to 16 separate blinds on one 16 channel remote
- Connection to Building Management System optional

### AUTOMATION

- Automated retraction in high winds
- Adjustable wind sensitivity levels
- Sun control via "Soliris" Sun & Wind or "Sunis" sun sensor

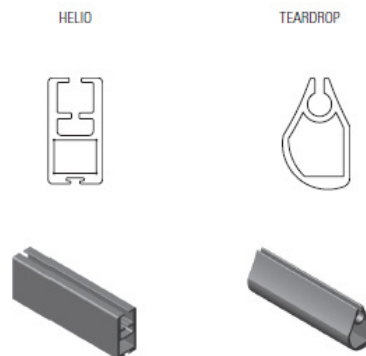

Basebar Types

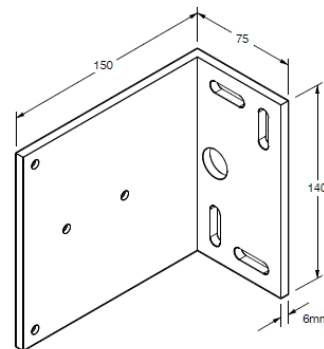

HM 130 00 mounting bracket