

# 1.21 OneBlind

## Technical Information

1. Outboard Kasset	Extruded aluminium manufactured to ISO9001.
2. Inboard Kasset	Extruded aluminium manufactured to ISO9001.
3. Tube	Mill finish ISO9001.
4. Round pin RT idle end	Mill finished extruded aluminium.
5. Roller tube splice	Mill finished extruded aluminium.
6. End guide plate	Anodised aluminium.
7. HDPE slide	U.V. stabilised nylon.
8. End cap	Pressed powdercoated steel.
9. HDPE Teflon cradle liner	Extruded powdercoated aluminium.
10. Ceiling pocket bracket	Extruded powdercoated aluminium.
11. Face fix bracket	Extruded aluminium manufactured to ISO9001.
12. Motor	To suit application.
13. Base rail	Extruded aluminium manufactured to ISO9001.

## Dimensions & Limitations

	80mm x 80mm	115mm x 115mm
MAXIMUM WIDTH*	12000mm	12000mm
MAXIMUM DROP*	5000mm	9000mm
CLEARANCE*	110mm x 110mm	140mm x 140mm

### \* Recommended Tolerances

## Standard Base Rail

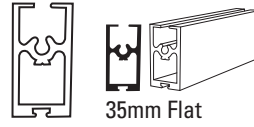

NOTE: Dimensions relate to height of Base Rail.

## Componentry (80mm and 110mm)

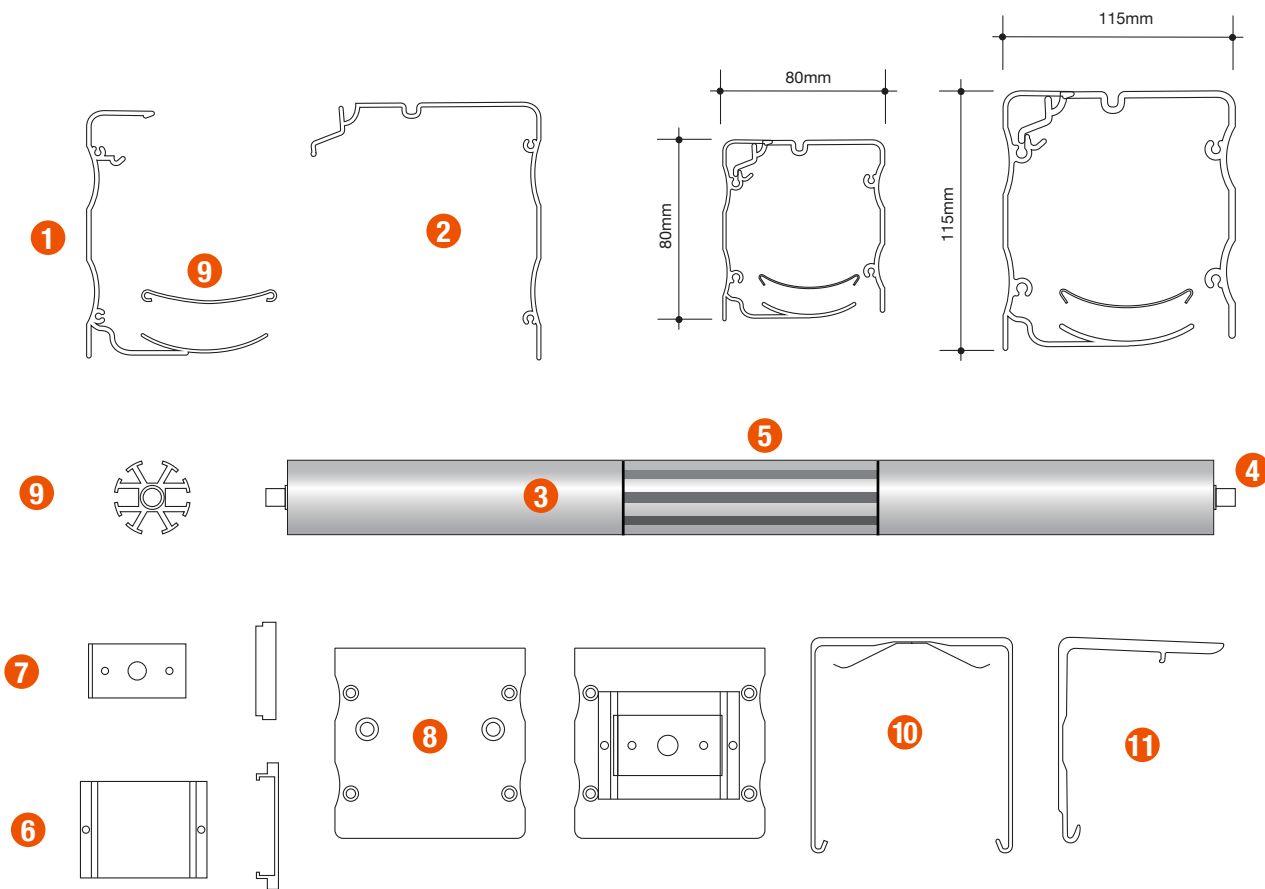

## Assembly

