

# INT - 3.21 SM 65 95 70

## INTERNAL AUTOMATED BLACKOUT SYSTEMS

MOTORISED BLACKOUT ROLLER BLIND SYSTEMS

### APPLICATION SM 65 95 70

The Helioscreen full blackout system is extremely versatile and is ideal for situations where a complete light block out is necessary like boardrooms and home theatres in both commercial and domestic applications. The system features stylish steel side channels with double internal brushes. This system is automated with a Somfy motor for the ultimate ease of use. The Warranty on the Helioscreen motorised Blackout system is 5-years.

### SYSTEM SPECIFICATIONS SM 65 95 70

<b>MINIMUM WIDTH</b>	800mm
<b>MAXIMUM WIDTH</b>	3000mm
<b>MAXIMUM DROP</b>	3200mm

### TECHNICAL INFORMATION SM 65 95 70

<b>HEAD BOX</b>	<ul style="list-style-type: none"><li>• Side brackets press formed steel, pre-treated and powder coated</li><li>• Bracket/head box projection 95mm</li><li>• Head box to be custom powder coated</li></ul>
<b>CONTROL END</b>	<ul style="list-style-type: none"><li>• Somfy motorised system</li><li>• Parts made with high strength fibreglass reinforced polyester and high carbon steel</li></ul>
<b>TUBE</b>	<ul style="list-style-type: none"><li>• 100% extruded aluminium</li><li>• 65mm outside diameter</li><li>• 2.0mm wall thickness</li></ul>
<b>SIDE CHANNELS</b>	<ul style="list-style-type: none"><li>• 70mm x 26mm blackout aluminium side channels with compressible blackout brush seal</li><li>• Side channels to be custom powder coated</li></ul>
<b>IDLE END</b>	<ul style="list-style-type: none"><li>• Comprises of an outside sleeve and centre shaft</li><li>• Roller rides on bearing surface</li></ul>
<b>BASE BAR</b>	<ul style="list-style-type: none"><li>• 18mm x 35mm extruded aluminium base bar helio style with compressible blackout brush seal</li><li>• Custom powder coating</li></ul>

INTELLIGENT  
SUN CONTROL  
SOLUTIONS®

# INT - 3.21 SM 65 95 70

## 2D DIAGRAM SM 65 95 70

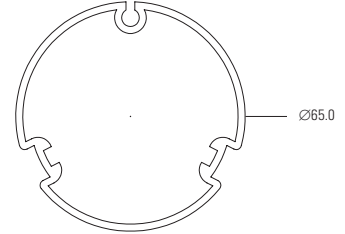
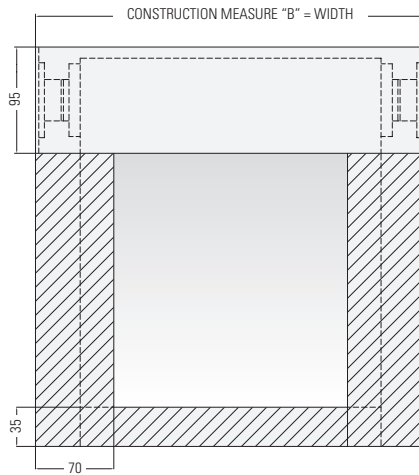

TUBE 65mm

## COMPONENTRY SM 65 95 70

70mm HEADBOX END CAP

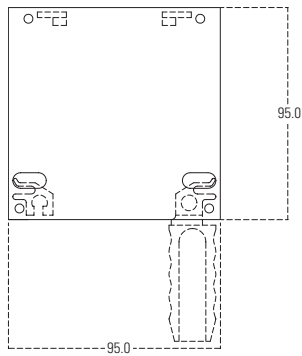

70mm SIDE CHANNEL

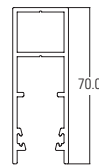

## BASE BAR SM 65 95 70

HELIO

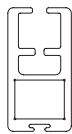

Helioscreen Australia Pty Ltd  
T +61 2 8426 1300  
F +61 2 9453 0744  
W [www.helioscreen.com.au](http://www.helioscreen.com.au)